

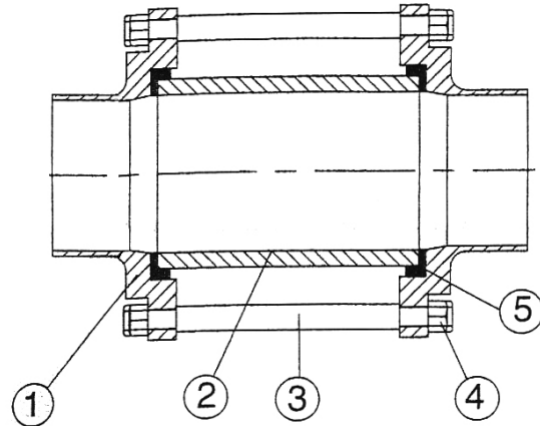

## Hygienic Sight Glass Range



No.	Part Name
1	Body
2	High Press Clean Glass
3	Screw Bolt
4	Nylon Lock Nut
5	Seal

## Glass Composition

Content	SiO <sub>2</sub>	Al <sub>2</sub> O <sub>3</sub>	Fe <sub>2</sub> O <sub>3</sub>	B <sub>2</sub> O <sub>3</sub>	Na <sub>2</sub> O	K <sub>2</sub> O
%	80.9	2.3	0.03	12.7	4.0	0.04

## Physical Properties

Description	Valve
Specific heat (25°C)	0.17 cal/g. °C
Average (25 - 400°C)	0.233cal/g. °C
Thermal Conductivity (25°C)	0.0026cal/cm.sec°C
(100°C)	0.0030cal/cm.sec°C
Linear coefficient of expansion (0-300?)	32.5x10 <sup>-7</sup> /°C
Density	2.23g/cm <sup>3</sup>

- Hygienic Sight Glass
  - Glass: Clean, high Press Glass. Max Work 10 bar. Can be changeable
  - Body: SS304, 316L Precision Machined Forged.
  - Screw Bolt: Full Stainless Steel.
  - Seal: EPDM
  - Full glass specification on request



# Berkeley Stainless Fittings Ltd.

. Bristol . Luton . Manchester . Oldbury . Swansea .

## Weld End Sight-Glass

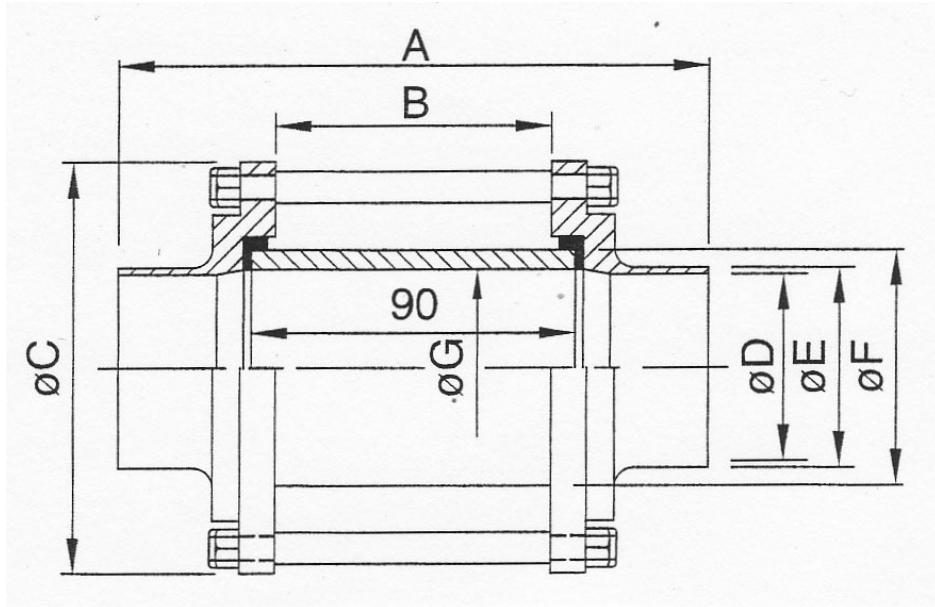

Size	A	B	C	D	E	F	G
1.0"	148	80	79	22.1	25.4	32	26
1.5"	156	80	85	34.9	38.1	40	34
2.0"	160	80	105	47.5	50.8	60	50
2.5"	160	80	112	60.2	63.5	75	65
3.0"	162	80	125	72.2	76.2	85	75.4